



TWIN-SPINDLE, TWIN-TURRET TURNING CENTERS WITH Y-AXES

PUMA TT

2500MS/SY



DN SOLUTIONS

PUMA TT2500 SERIES

High performance turning center featuring first & second spindle that have the same power and capacity, with upper & lower turrets on the grounded box type bed. Simultaneous machining on two faces with both spindles and turrets and virtual realization of Y-axis function will bring you double productivity.



The compact PUMA TT is packed with one-setup efficiency. Thanks to its 24 tool positions in the upper and lower turrets, you'll complete complicated parts that require plenty of tools in just one setup.



EXCELLENT RIGIDITY AND POWER

The left and right spindles and the upper and lower turrets operate independently to double the machine's productivity.

DOUBLED PRODUCTIVITY

All guide ways are wide wraparound rectangular type for unsurpassed long term rigidity and accuracy.

ADVANCED AUTOMATION

The left and right spindles are equipped with independent parts catcher and unloading/conveyor systems for fully-automated operation.

BASIC STRUCTURE

Machine construction

Perfect integration of multi-process and high productivity are achieved by Left & right spindle of the same power and capacity, with upper & lower turrets on the grounded box type bed.

Achievement of PUMA TT machines

Continuous process accuracy, Shorten setting time, Optimal distribution of cycle and Automated works.

Outstanding rigidity for high feedrates

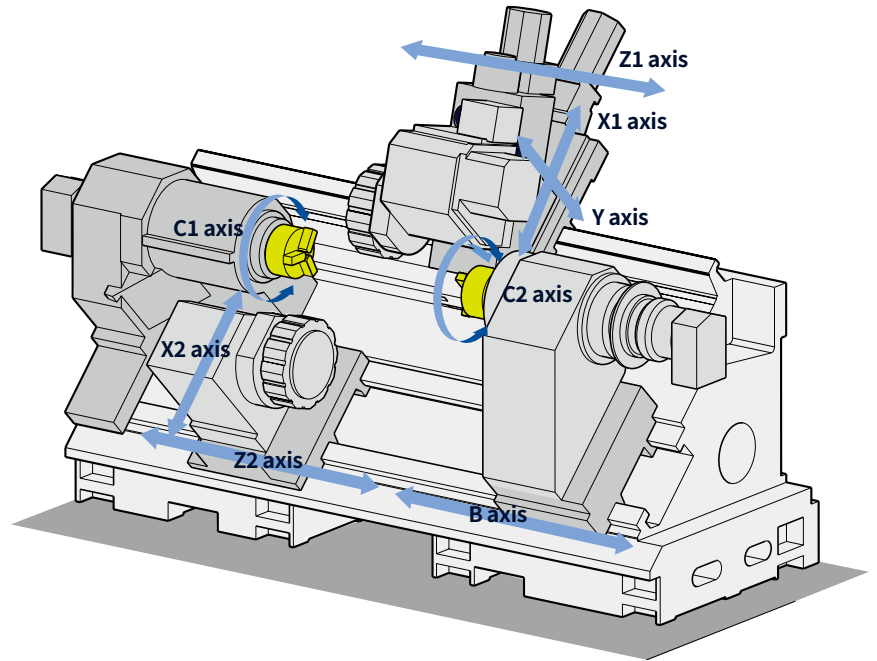

Travel

X1-axis (Upper turret)

255 mm
10.0 inch

Z1-axis (Upper turret)

800 mm
31.5 inch

A-axis

810 mm
31.9 inch

Rapid traverse

X-axis

20 m/min
787.4 ipm

Z-axis

24 m/min
944.9 ipm

X2-axis (Lower turret)

190 mm
7.5 inch

Z2-axis (Lower turret)

900 mm
35.4 inch

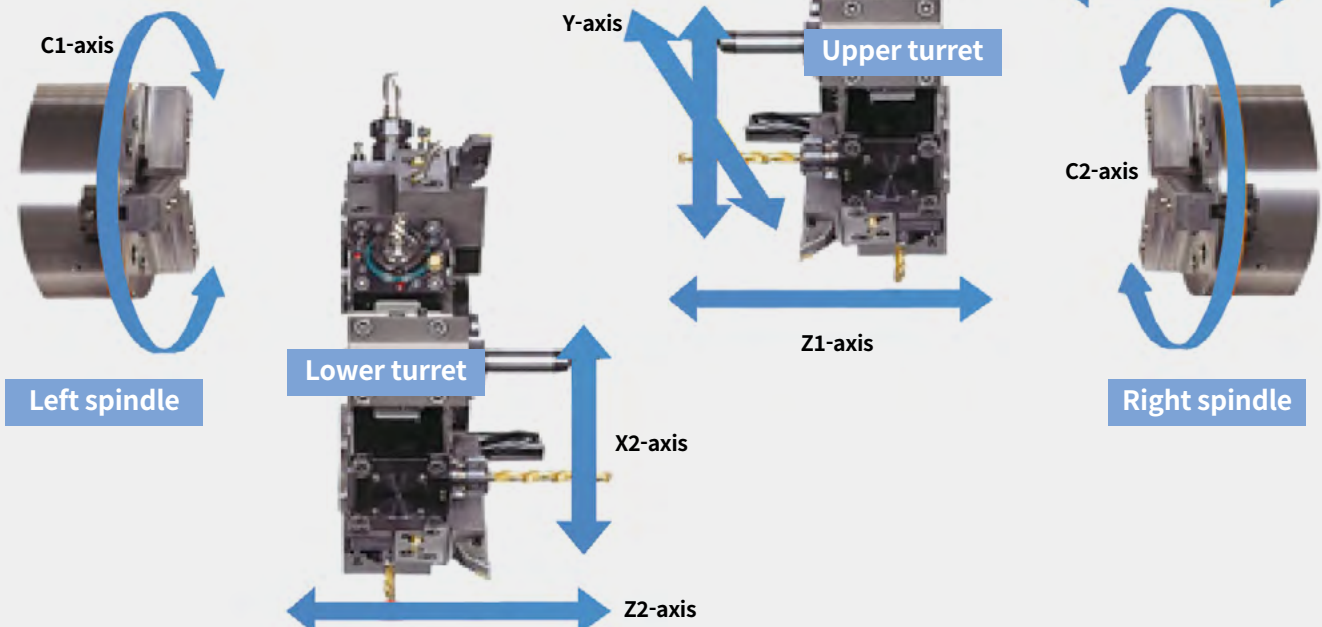

FLEXIBLE MACHINING

PUMA TT2500SY A versatile performer

A : Max. turning dia. (on Upper turret)

390 mm
15.4 inch

A : Max. turning dia. (on Lower turret)

300 mm
11.8 inch

B : Max. turning length

350 mm
13.8 inch

C : Max. bar working dia. (Left spindle)

81 mm
3.2 inch

C : Max. bar working dia. (Right spindle)

76 mm
3.0 inch

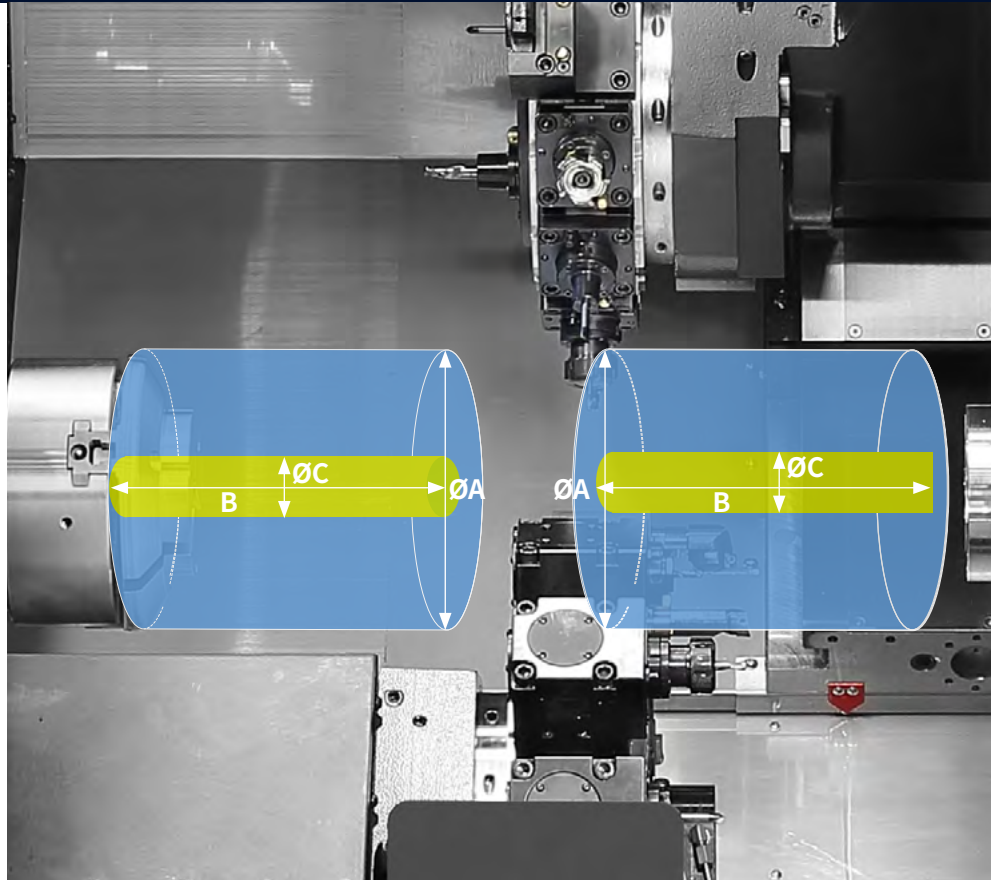

Y-axis working range

By simultaneous X-Y-Z-axis feed control and C-axis function to guide precise circular orientation of spindle, Y/X axes circular interpolation simplifies the machining of complex shapes in faster cycle time.

Y-axis travel

120 (±60) mm
4.7 (±2.4) inch

Y-axis rapid

7.5 m/min
295.3 ipm

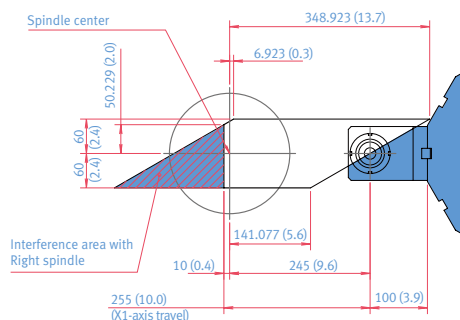

Angular Milling unit moving area

Y-axis milling

A wide variety of multi-axis milling cycles can be achieved using the Y-axis.

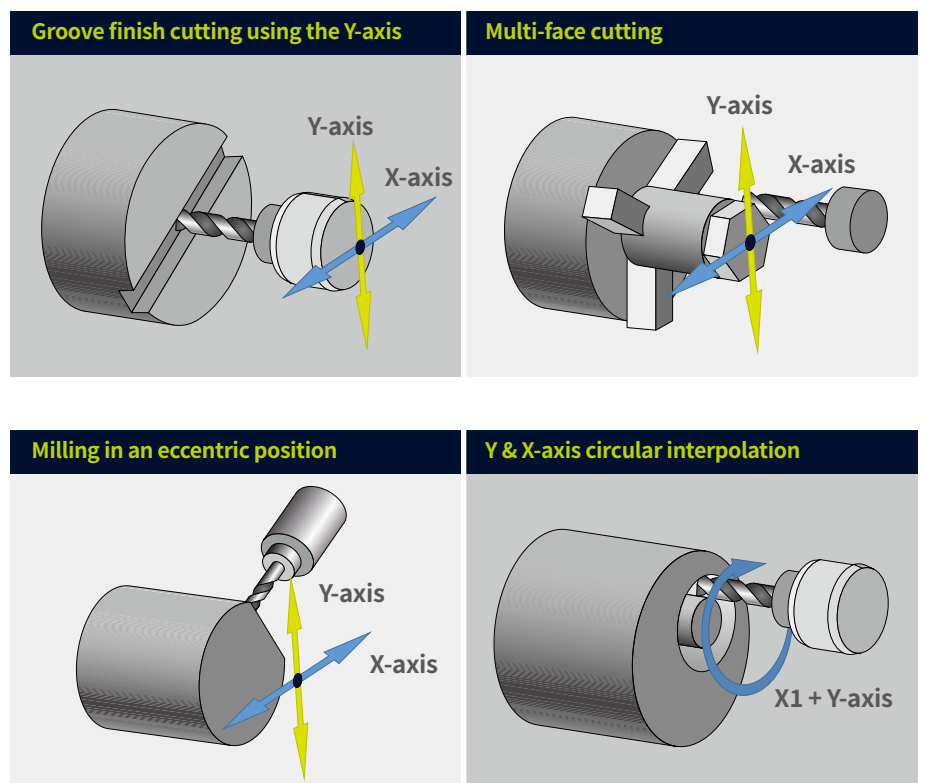

SPINDLE

High-speed and high-power spindle delivers impressive productivity.

Built-in design

Both left and right spindle have built-in motor spindles that wholly covered with oil cooling system to ensure remarkable range of applications from heavy duty cutting with high power at low speed to fine to finish cutting at high speed and optimize thermal displacement. Both Left and Right spindle are designed to minimize maleffects of thermal distortion which can hit continuous machining precision seriously. Especially the same capacity of both spindles improves productivity remarkably of single machine.

Max. power (30 min)

26 / 22 kW

Max. spindle speed (10inch)

4000 r/min

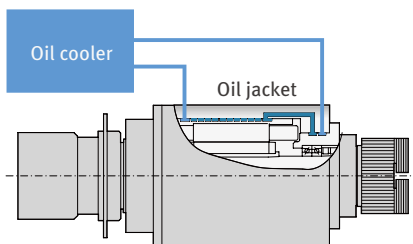

Oil cooling unit for spindles



C-axis accuracy

The positioning and repeatability of the C-axis has been enhanced.

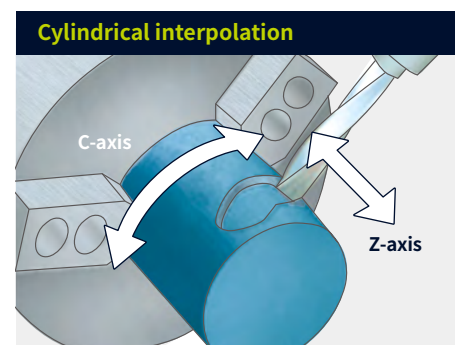
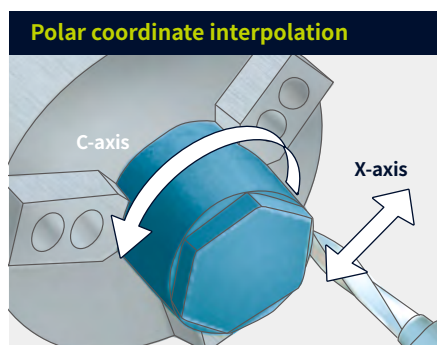

TURRETS

Featuring stronger and faster turrets; upgraded servo motors for faster and more accurate tool rotation; and a stabilized structure for higher productivity and heavier-cutting capabilities.

Index time (1-station swivel)

0.20 s

No. of tool stations (Upper+Lower turret)

24 (12+12) st

Turret with upgraded speed and rigidity

Total of 24 tool stations upper and lower turret(BMT65P) make it possible to complete complicated parts requiring many tools in just one set-up. Reliable servo driven turrets reduce the total cycle time required to machine parts.

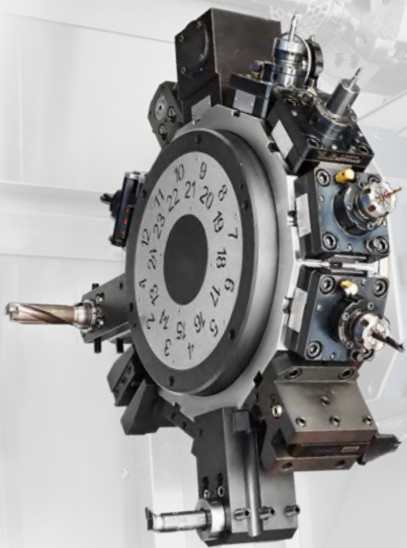
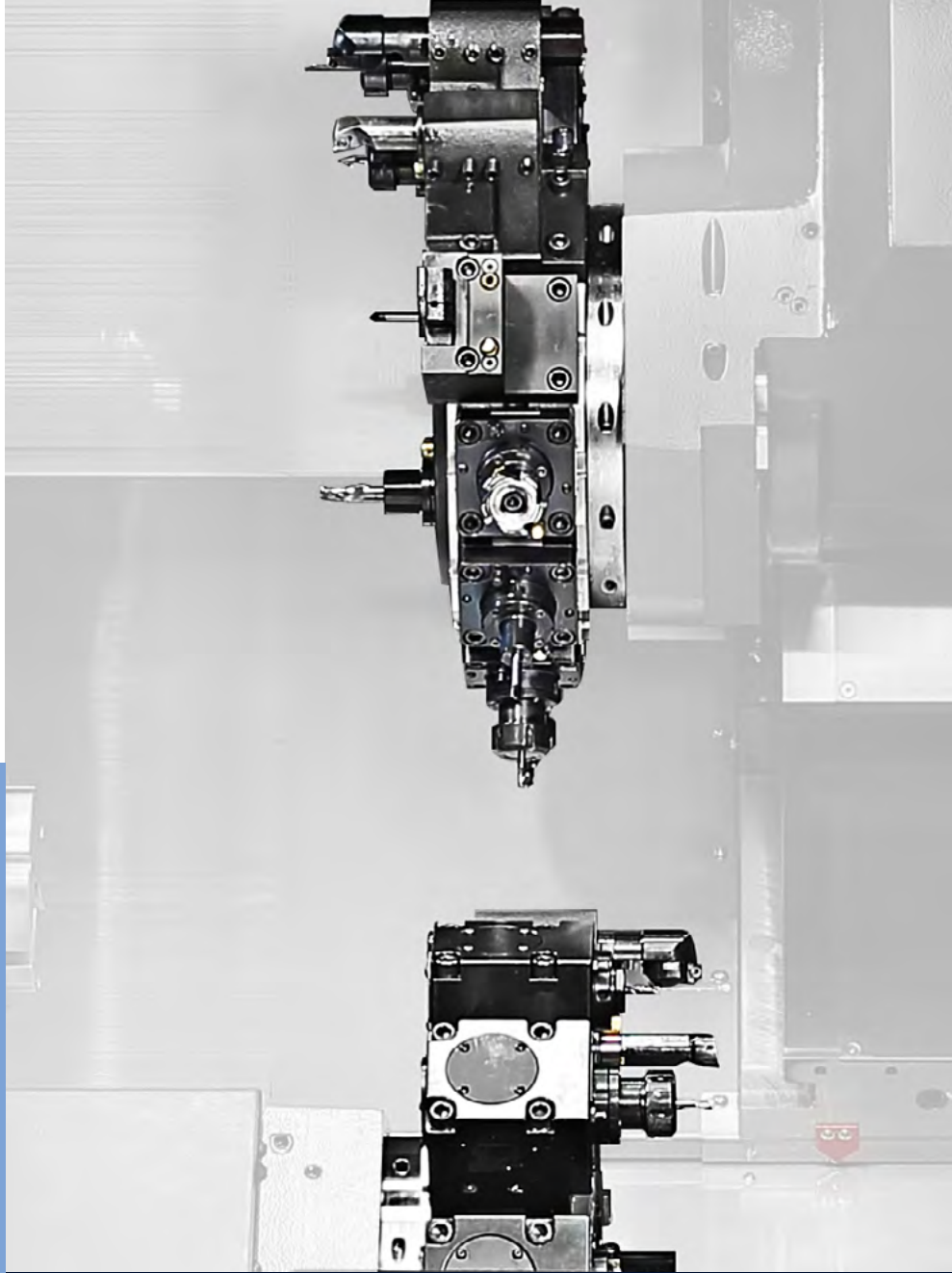

Radial BMT65P

The turret features BMT65P style tooling in which the toolholders are mounted directly to the turret's periphery using 4 large bolts.

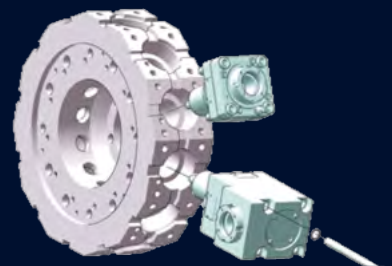

MACHINE CAPACITY

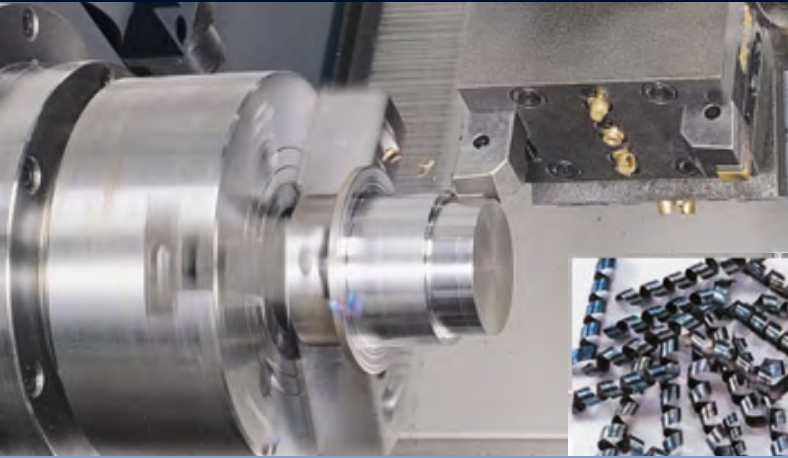

Heavy-duty cutting, OD (Left spindle & upper turret)

Making full use of the high output motor, heavy-duty O.D. cutting is powerful and precise even with large workpieces.



Balanced cutting, OD (Left spindle & upper - lower turret)

The synchronous control of Upper and Lower turrets makes O.D. cutting with high precision balanced cutting.

Chip removal rate

348 cm³/min
21.2 inch³/min

Cutting depth

10 mm
0.4 inch

Material	Cutting speed (m/min (ipm))	Feedrate (mm/rev (ipr))	Spindle speed (r/min)
SM45C	120 (4724.4)	0.36 (0.0)	320

Chip removal rate

367 cm³/min
22.4 inch³/min

Cutting depth

5 mm x 2
0.2 inch

Material	Cutting speed (m/min (ipm))	Feedrate (mm/rev (ipr))	Spindle speed (r/min)
SM45C	120 (4724.4)	0.4 (0.0)	320

Reliable Long-Run Machining Accuracy

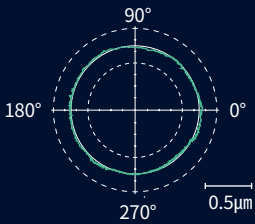

Tool	Ø 20 HSS drill
Material	AL2024
Outer diameter (mm (inch))	60 (2.4)
Spindle speed (r/min)	1300
Feedrate (mm/rev (ipr))	0.05 (0.0)

Roughness

0.40 μm

Surface roughness

0.23 μmRa

*The machining accuracy indicated is just for reference. Depending on cutting and environmental conditions during measurement, the results can be different..

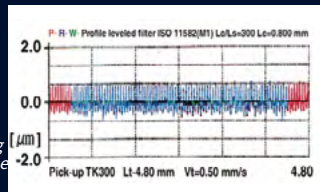

Drilling

Tool	Ø 20 HSS drill
Material	SM45C
Rotary tool spindle speed (r/min)	1,000
Feedrate (mm/min)	0.3 (0.0)
Chip removal rate (cm ³ /min (inch ³ /min))	60 (3.7)
Drilling depth (mm (inch))	10 (0.4)

Tapping

Tool	M16×2.0
Material	SM45C (JIS S45C)
Rotary tool spindle speed (r/min)	600
Feedrate (mm/min (ipm))	1200 (47.2)

Machining examples

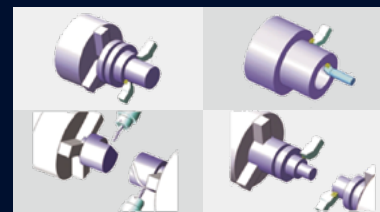

High productivity

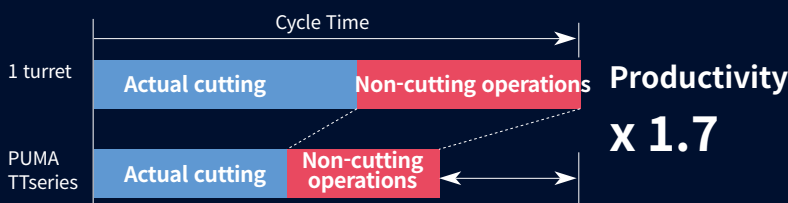

STANDARD | OPTIONAL SPECIFICATIONS

A range of options is available to suit individual requirements.

Description	Features	PUMA TT2500series
Chuck (Left / Right)	Plunger stroke: MH210 (19)/Cylinder stroke: SD-18582 (30)	●
	None	○
Jaws (Left / Right)	Soft Jaws	●
	Hardened & ground hard Jaws	○
Chucking option	Dual pressure chucking	○
	Chuck clamp confirmation	○
Tailstock	Tail center for turret	○
Coolant pump	1.5 bar	●
	4.5 / 7 / 10 / 14.5 / 20 / 70 bar	○
Coolant options	Oil skimmer	○
	Coolant chiller	○
	Coolant pressure switch	○
	Cooling flow switch	○
	High coolant Interface	○
	Chuck coolant (Left / Right)	○
	Through spindle coolant(T.S.C) for spindle (Left / Right)	○
Chip processing options	Coolant gun	○
	Chip conveyor_Side type	○
	Chip conveyor_Rear type	○
	Chip bucket	○
	Air blow (Left / Right)	●
Measurement & automation	Mist collector	○
	Tool setter (Manual –removable type / Auto)	○
	Parts catcher and box	X
	Parts unloader and conveyor	○
	Work ejector	○
	Auto door	○
	Cut-off confirmation	○
	Work / Tool counter	○
Optional devices	Robot interface (PMC I/O, Profibus)	○
	Bar feeder interface	○
	Tool Load Monitoring	○
	Linear scale (X1, X2)	○
	Signal tower	○
	Air gun	○
	Air conditioner for electric cabinet	○
	Light for electric cabinet	○
	Extra M-code (4ea)	○
	Auto power off	○
Customized special option	Quick change tooling(CAPTO)	○
	Coolant level switch : Sensing level - Low	○
	Parts unloader and conveyor_Grippertype	○
	Automatic top door	○
	Coolant gun	○
	Coolant chiller	○
	Chip conveyer_drum filter type	○
	Shower coolant	○
	Air limit sensing on chuck_Preparation	○
	Rotary type window wiper_Eletrical	○
	TSCfor Main/Left spindle	○
	TSC for Sub/Right spindle	○
	TSA for Main/Left spindle	○
	TSA for Sub/Right spindle	○
	Work & tool counter	○
	Tool setter extension for special chuck	○
	Main/Left spindle air curtain	○
Sub/Right spindle air curtain	○	
MQL System	○	
Chuck Pressure Switch	○	

Please contact your DN Solutions representative for detailed machine information.

● Standard ○ Optional X N/A



**Fire Safety
Precautions**

There is a high risk of fire when using non-water-soluble cutting fluids, processing flammable materials, neglecting the controlled and careful use of coolants and modifying the machine without the consent of the manufacturer. Always check the SAFETY GUIDELINES carefully before using the machine.

PERIPHERAL EQUIPMENT

Ergonomic design

Swivel type operator panel

Operator oriented design with 90° swivel

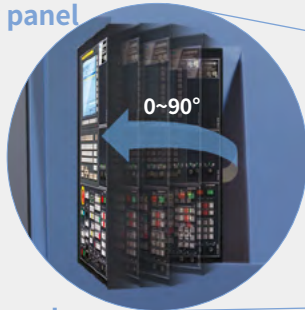

Safety window on front door

Viewing window is designed and was tested under heavy condition to protect operator against possible dangers during real cutting thanks to its shock absorbing laminated glass and double panel construction. The window without grating also provides a clear view of the machine inside.

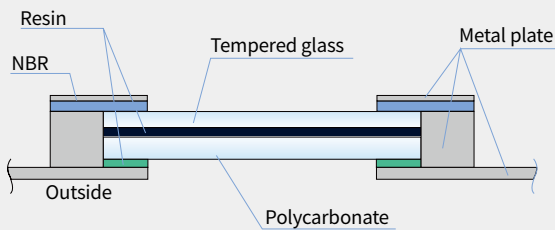

High maintainability

Pressure control for Left spindle chucking

Pressure control for right spindle chucking (or Tail stock)

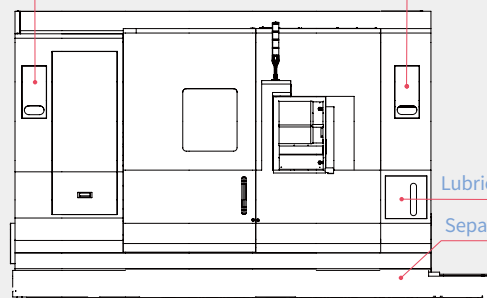

Eco-friendly design

Oil skimmer OPTION

Another suggestion to prolong the life time of the coolant water. A belt-driven type oil skimmer picks up and removes waste oil from the coolant tank that is easily drained.

Collection of waste lubrication Oil

Less waste lubrication oil extends the life time of the coolant water and cut down the grime and offensive smell of the machine inside.

No coolant leakage

Rigorously designed, manufactured and tested machine covers do not permit coolant leakage in any condition. The factory always keeps our environment clean.

Coolant chiller (recommended) OPTION

Coolant chiller is highly recommended to prevent temperature rise and minimize thermal deformation, when using a water-insoluble coolant or high-pressure coolant system of which the power is over 1.5 kw.

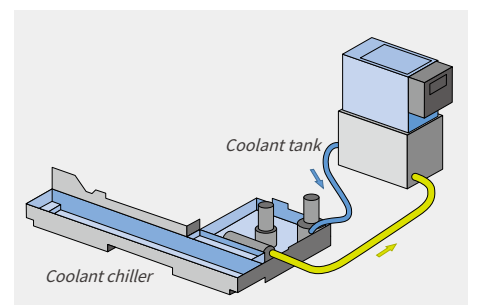

PERIPHERAL EQUIPMENT

Optimal support system of automatic operation OPTION

Parts unloader & conveyor

Parts unloader system built inside the machine can receive workpieces from both spindles. Automated operation is realized perfectly when the system is coupled with bar feeder system.

Max. work diameter	Ø81 mm (3.2 inch)
Max. work length	160 mm (6.3 inch)
Max. work weight	4kg (8.8 lb)

Bar feeder system

Automated bar working is possible by bar feeder system. When parts unloader system is added, its value of use will be in the best.

Max. bar working dia

Ø81 mm
3.2 inch

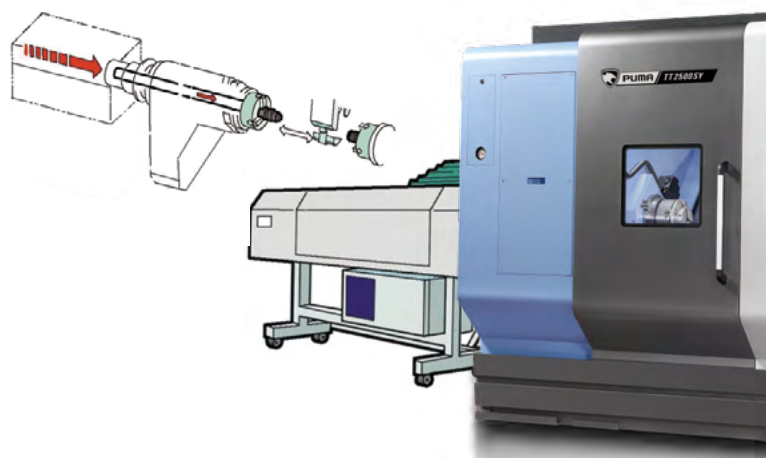
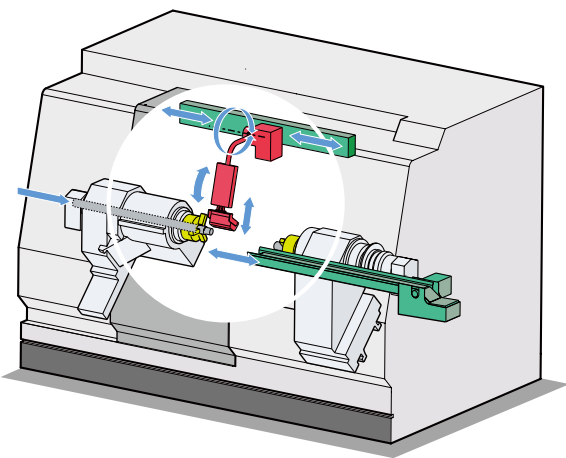

** Depending on the chuck and cylinder spec. used in the machine, the bar working dia. can be reduced.*

Optional equipment

Auto tool setter



Coolant blower



Signal tower



Collet chuck



ID/OD special holder
(each turret 12ea/tool 24ea)

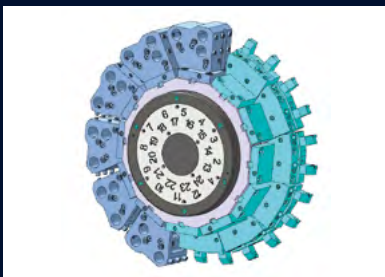

Milling special holder
(each turret 12ea/tool 24ea)

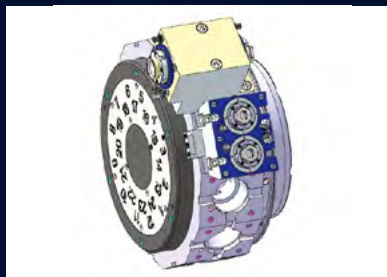

Work ejector

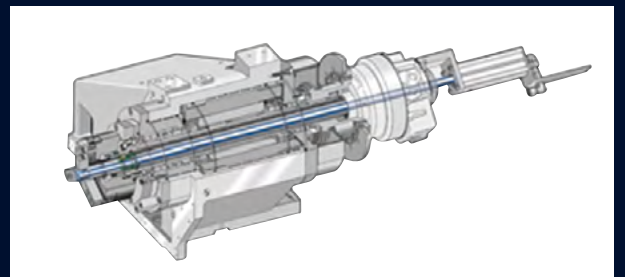

DN SOLUTIONS FANUC i PLUS

DN Solutions Fanuc i Plus maximizes customer productivity and convenience.

15" Screen + New OP

DN Solutions Fanuc i Plus' operation panel enhances operating convenience by incorporating common-design buttons and layout. It features a Qwerty keyboard for fast and easy data input and operation.

DN Solutions Fanuc i Plus

- 15-inch color display
- Intuitive and user-friendly design

USB and PCMCIA card QWERTY keyboard

- EZ-Guide i standard
- Ergonomic operator panel
- 2MB Memory
- Hot keys



iHMI touchscreen OPTION

iHMI provides an intuitive interface that uses a touchscreen for quick and easy operation.

Range of applications

Providing various applications related to planning, machining, improvement and utility, for customer convenience.

Real-time custom macro function OPTION

During operation of the parts unloader of the right spindle, this function allows the lower turret to conduct the cutting operation for the left spindle. This function also further improves the productivity.

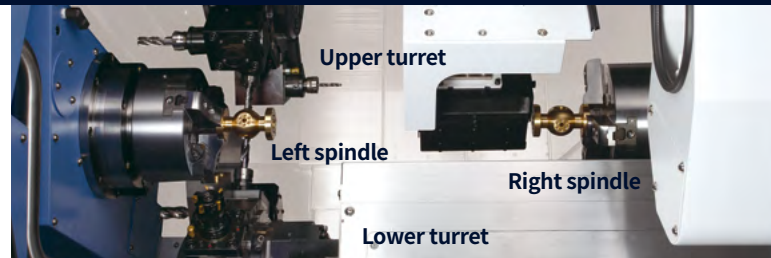

NUMERIC CONTROL SPECIFICATIONS

FANUC

Division	Item	Specifications	MS	SY
			DN Solutions Fanuc i Plus	DN Solutions Fanuc i Plus
Controlled axis	Controlled axes		7 (X1,Z1,C1, X2,Z2C2,A)	8 (X1,Z1,C1,Y, X2,Z2,C2,A)
	Simultaneously controlled axes		4 axes (each path)	4 axes (each path)
Data input/output	Fast data server		○	○
	Memory card input/output		●	●
	USB memory input/output		●	●
	Large capacity memory(2GB)	Only with Fanuc i Plus iHMI	○	○
Interface function	Embedded ethernet		●	●
	Fast Ethernet		○	○
	Enhanced embedded ethernet function		●	●
Operation	DNC operation	Included in RS232C interface.	●	●
	DNC operation with memory card		●	●
Program input	Workpiece coordinate system	G52 - G59	●	●
Feed function	AI contour control I	G5.1 Q _z , 40 Blocks	●	●
	AI contour control II	G5.1 Q _z , 200 Blocks	○	○
Operation guidance function	EZ Guidei (Conversational programming solution)		●	●
	iHMI with machining cycle	Note *1) Only with 15" touch LCD standard	○ *1)	○ *1)
	Multi path function	Supporting 2 or 3 path machine	●	●
Setting and display	EZ Operation package		●	●
	CNC screen dual display function		●	●
Network	FANUC MTConnect		✳	✳
	FANUC OPC UA		✳	✳
Others	Display unit	15" color LCD	●	●
		15" color LCD with touch panel	○	○
	Part program storage size & Number of registerable programs	1280M(512KB)_1000 programs	X	X
		5120M(2MB)_1000 programs	●	●

● Standard ● Optional X N/A ○ Available

DN SOLUTIONS FANUC i PLUS

EZ-Guide i

Using the DN Solutions EZ-Guide i, users can create a cutting program for any desired shape, including patterns, by entering just the dimensions.

Example programming : Cutting shape

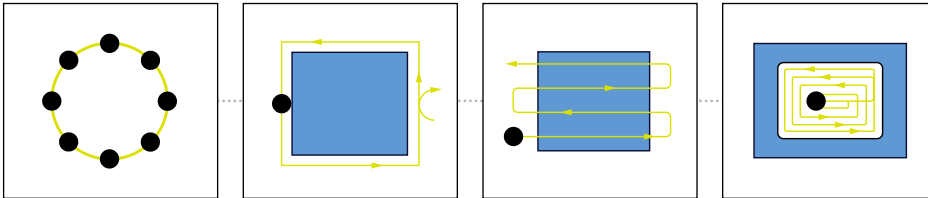

Example part

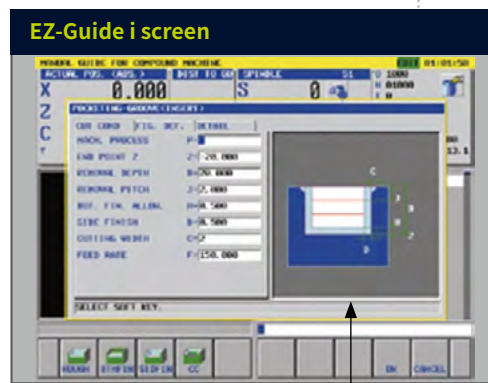
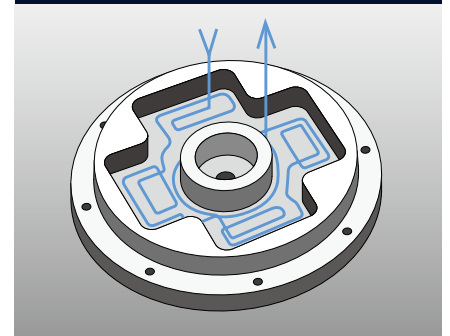

Enter the dimensions of the shape

Automatic creation of cutting program

```
O7000 (SAMPLE PROGRAM) ;
...
M3 S1500 ;
G0 X50. Y125. ;
G0 Z30. ;
G1040 T0.5 J3. H0.2 K0.5 ... ;
G1020 H120. V50. U37. W68. ... ;
G0 Z80. ;
M5 ;
```

A cutting program is automatically created with the entered values.

EZ Work

DN Solutions's EZ Work supports the user with functions relating to tool data, error diagnostics, set up and machine monitoring.

Tool monitoring screen



Tool load monitoring function

During cutting operation, abnormal load caused by wear or damage of the tool is detected and an alarm is triggered to prevent further damage.

Parts unloader maintenance and service screen



Convenience of maintenance and service

The condition and service procedures of the sensors are provided for easy maintenance and servicing of major units.

Q-setter Automatic measurement



Crash avoid check

Set the interference area between turret and sub spindle to avoid collision.



Tool management



Convenient set up for peripheral equipment

Helps tool setter guide, work setting, tailstock setting, and other measurement and parameter control to reduce setting-up time and facilitates operation.

POWER | TORQUE

PUMA TT2500MS/SY

Max. spindle speed : **4000** r/min

Max. power : **26** kW
34.9 Hp

Max Torque : **521** N·m
384.3 ft-lbs

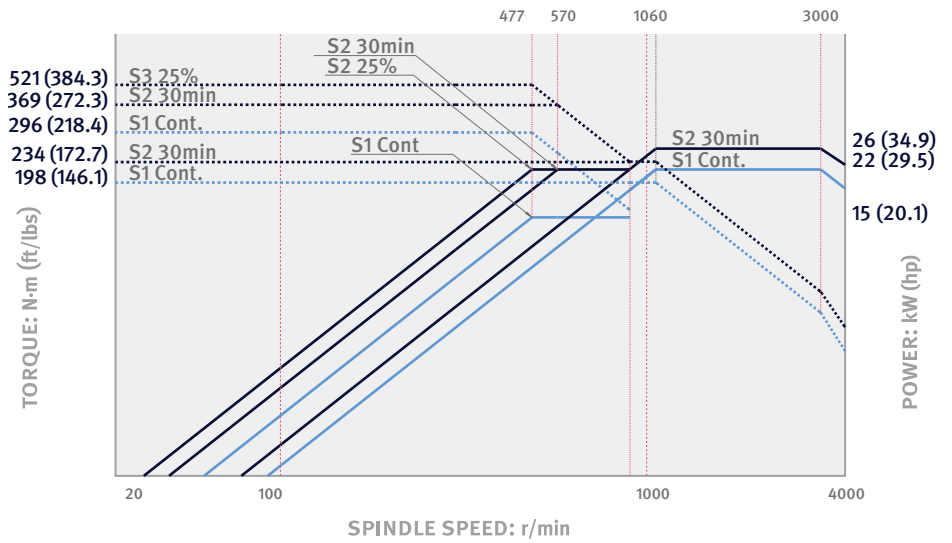

Rotary tool spindle PUMA TT2500MS/SY

Max. spindle speed : **5000** r/min

Max. power : **5.5/1.5** kW
7.4/2.0 Hp

Max Torque : **48** N·m
35.4 ft-lbs

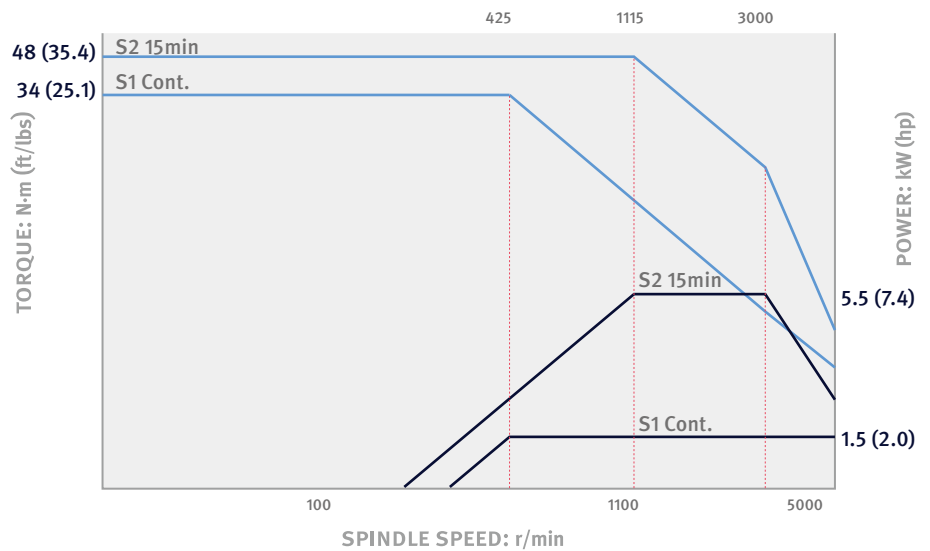

Rotary tool spindle PUMA TT2500MS/SY OPTION

Max. spindle speed : **5000** r/min

Max. power : **7.5/1.5** kW
7.4/2.0 Hp

Max Torque : **95.5** N·m
70.5 ft-lbs

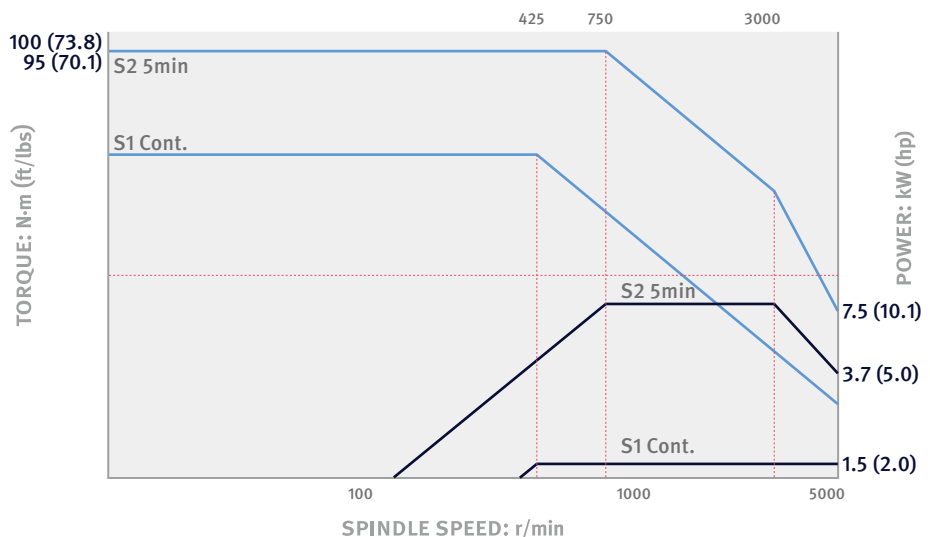

EXTERNAL DIMENSIONS

PUMA TT2500 MS / SY

TOP

Unit : mm (inch)

Coolant tank direction	Length 'A'(mm)
Right side coolant tank	1210 (47.6)
Rear side coolant tank	1310 (51.6)

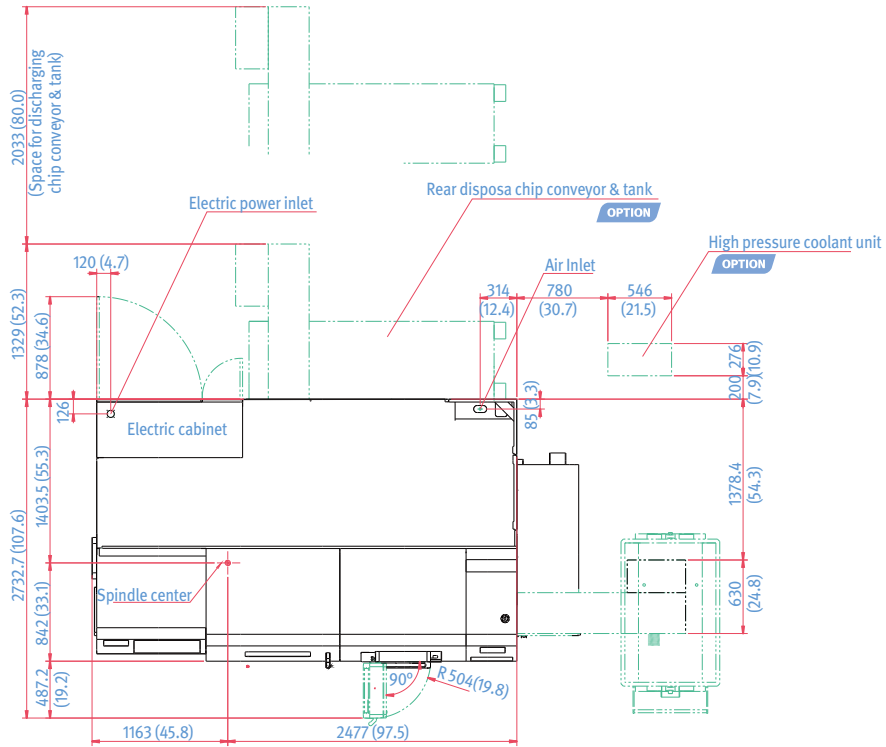

FRONT

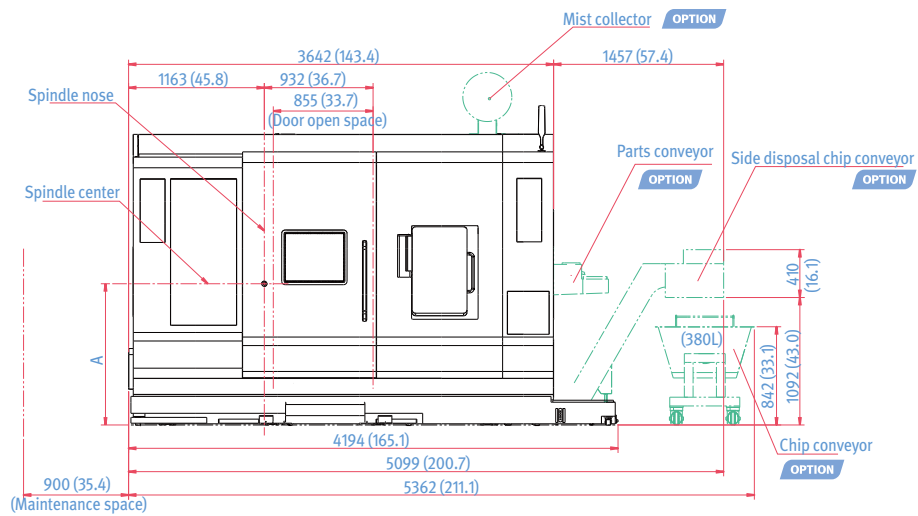

SIDE

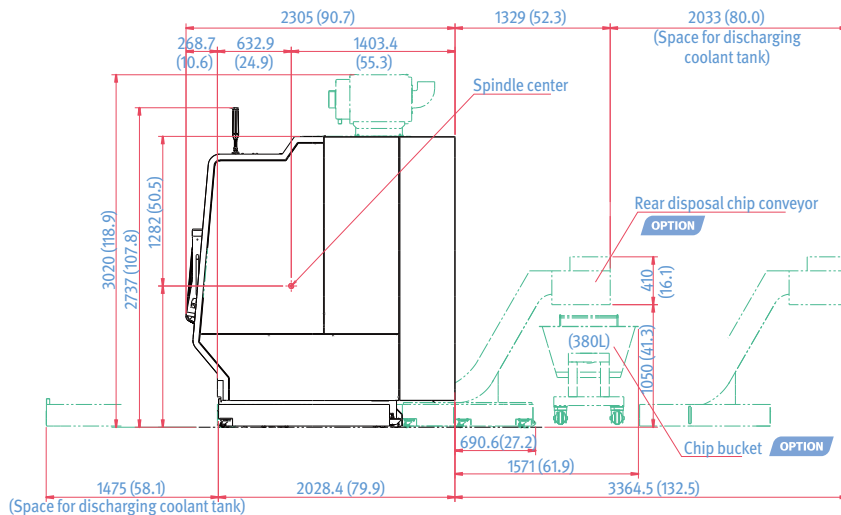

* Some peripheral equipment can be placed in other areas.

TOOLING SYSTEM

PUMA TT2500 MS / SY

Unit : mm (inch)

Standard

* () Supply quantity

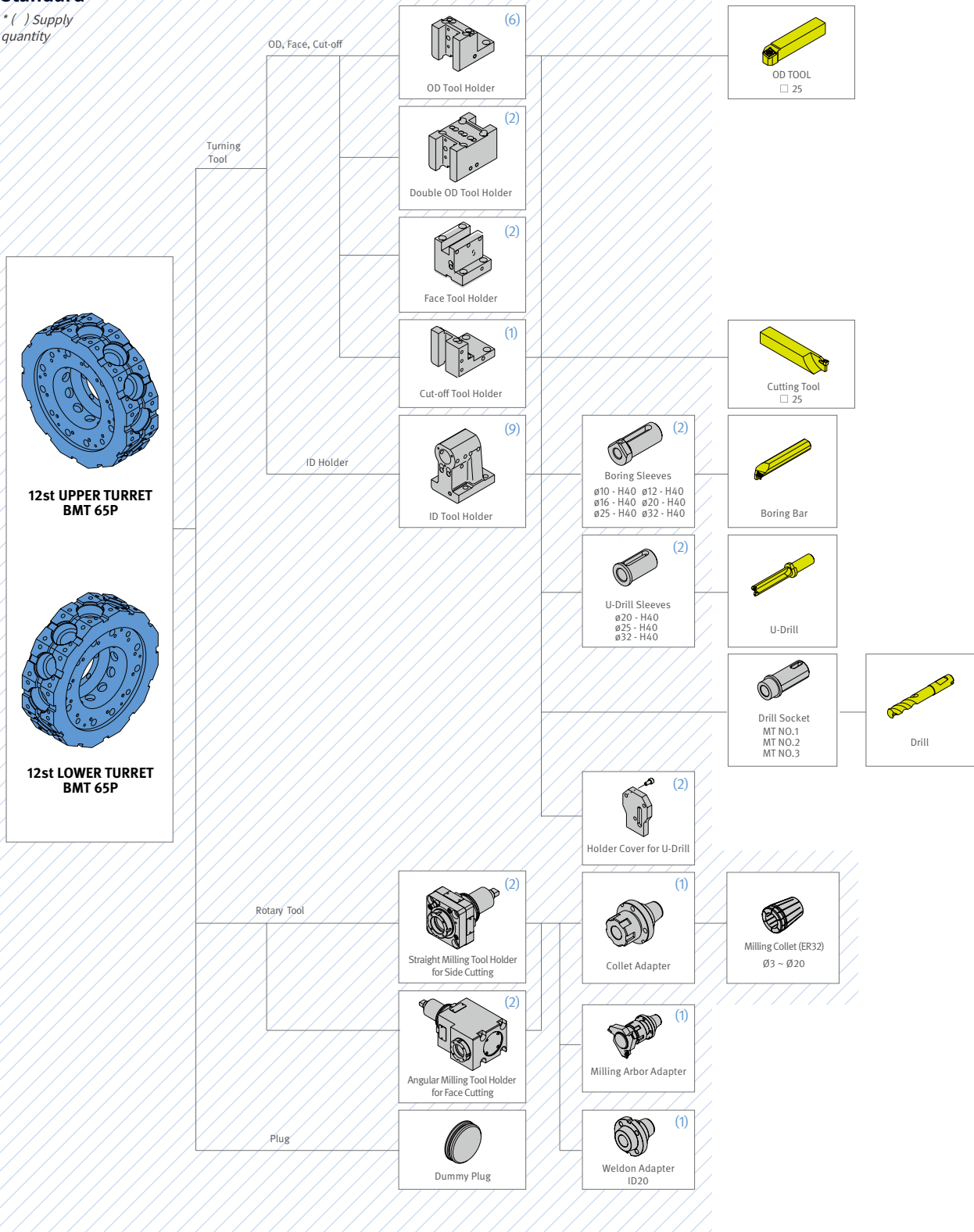

TOOL INTERFERENCE DIAGRAM

PUMA TT2500 MS / SY

Unit : mm (inch)

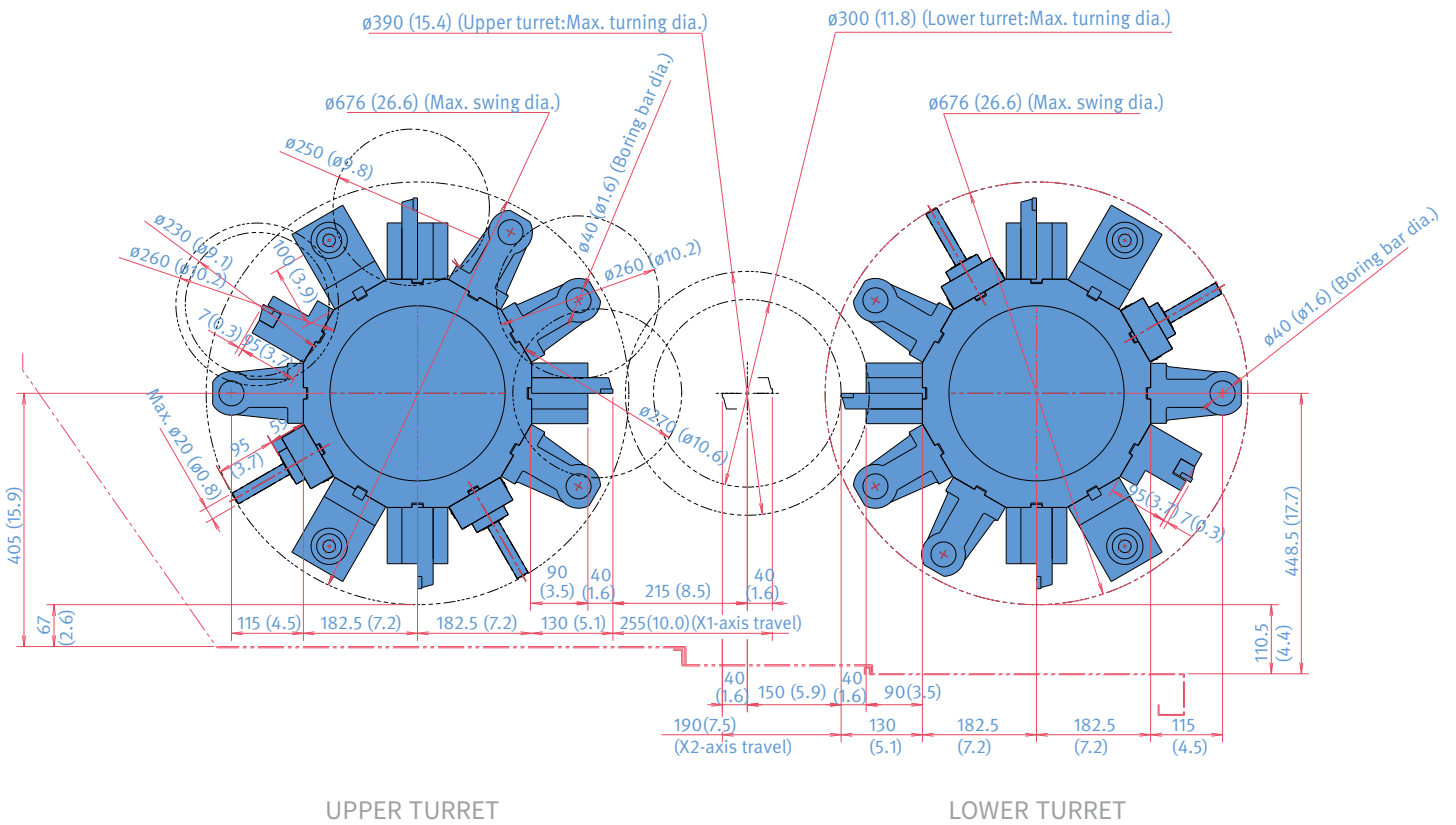

WORKING RANGE DIAGRAM

PUMA TT2500 MS / SY

Unit : mm (inch)

SINGLE OD TOOL HOLDER

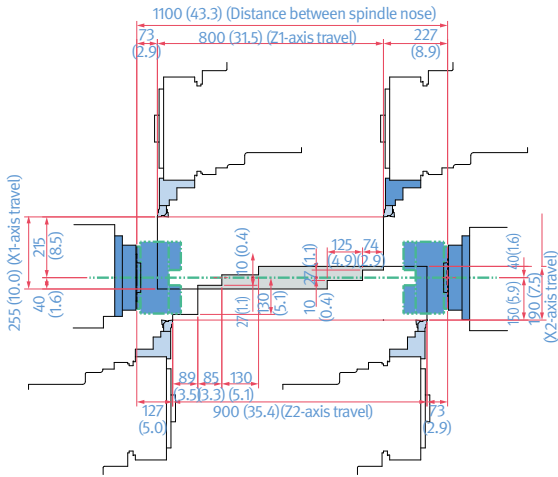

DOUBLE OD TOOL HOLDER

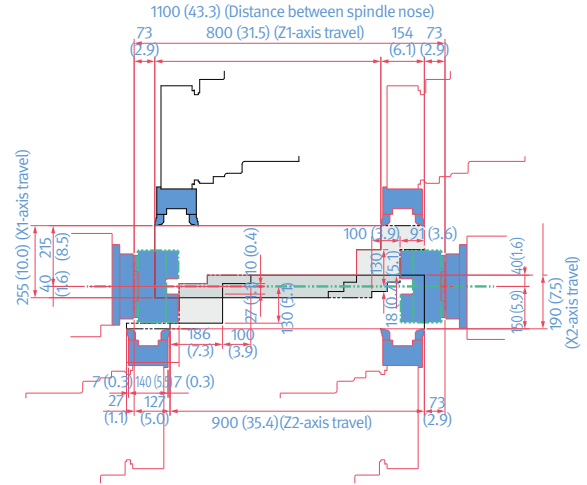

SINGLE ID TOOL HOLDER

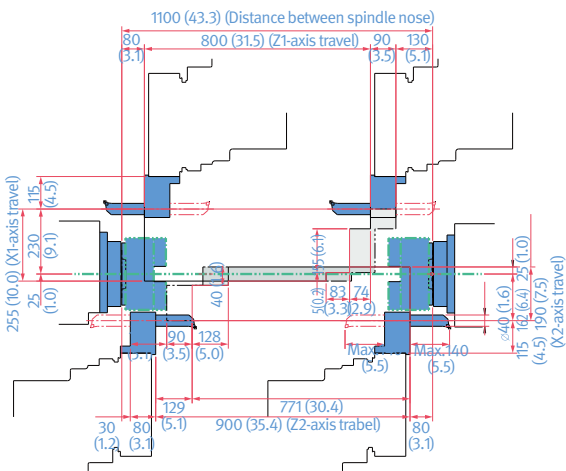

ANGULAR MILLING HEAD

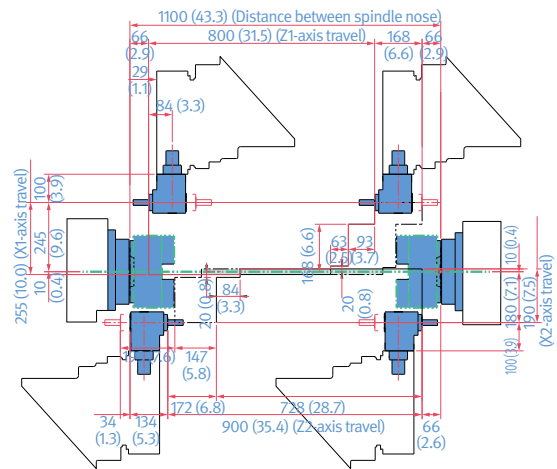

STRAIGHT MILLING HEAD

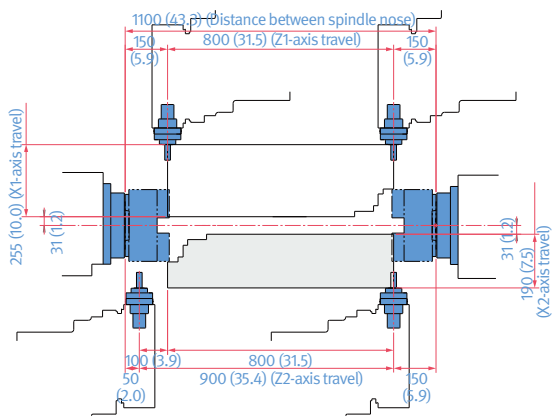

Y axis TRAVEL DISTANCE

Angular milling head

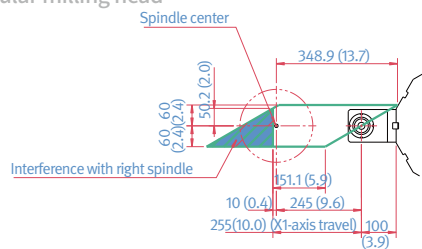

Straight milling head

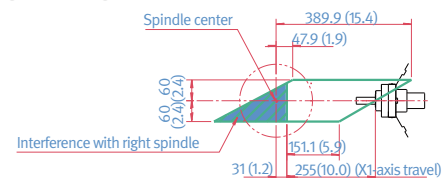

MACHINE SPECIFICATIONS

PUMA TT2500 MS / SY

Description		Unit	PUMA TT2500MS	PUMA TT2500SY	
Capacity	Swing over bed		mm (inch)	800 (31.5)	
	Swing over saddle		mm (inch)	620 (24.4)	
	Max. turning diameter	On upper turret	mm (inch)	390 (15.4)	
		On lower turret	mm (inch)	300 (11.8)	
	Recommended turning diameter		mm (inch)	255 (10.0)	
	Max. turning length		mm (inch)	350 (13.8)	
	Bar working diameter		mm (inch)	81 (3.2)	
Spindle (Left/Right)	Spindle speed		r/min	4000	
	Spindle nose		ASA	A2-8	
	Spindle bearing diameter (front)		mm (inch)	130 (5.1)	
	Spindle through hole diameter		mm (inch)	Left/Right: 91 (3.6)	
	C1-axis minimum indexing increment		deg	0.001	
Travels	X1-axis		mm (inch)	255 (10.0)	
	Z1-axis		mm (inch)	800 (31.5)	
	A-axis		mm (inch)	810 (31.9)	
	X2-axis		mm (inch)	190 (7.5)	
	Z2-axis		mm (inch)	900 (35.4)	
	C1, C2-axis		deg	360	
	Y-axis		mm (inch)	-	120 (±60) (4.7 (±2.4))
Rapid traverse rate	X1, 2-axis		m/min (ipm)	20 (787.4)	
	Z1, 2-axis		m/min (ipm)	24 (944.9)	
	A-axis		m/min (ipm)	24 (944.9)	
	C1, C2-axis		r/min	-	200
	Y-axis		m/min (ipm)	-	75 (2952.8)
Turret (Upper/Lower)	Number of tool stations		ea	12	
	OD tool size		mm (inch)	25 x 25 (1.0 x 1.0)	
	Max. boring bar size		mm (inch)	Ø40 (Ø1.6)	
	Turret indexing time	1 station swivel	sec	0.2	
	Max. rotary tool speed		r/min	5000	
Motor	Spindle motor power (Left/Right)		kW (Hp)	26 / 22 (34.9 / 29.5) (30min/Cont.)	
	Servo motor power	X1-axis	kW (Hp)	4 (5.4)	
		X2-axis	kW (Hp)	3 (4.0)	
		Z1, 2-axis	kW (Hp)	4 (5.4)	
		A-axis	kW (Hp)	4 (5.4)	
		Y-axis	kW (Hp)	-	3 (4.0)
Coolant pump motor power		kW (Hp)	0.4 (0.5)		
Power source	Required power capacity		kVA	86.81	
Machine dimensions	Machine size	Floor space	mm (inch)	4220 x 2360 (166 x 87)	
		Height	mm (inch)	2340 (92)	2490 (98)
	Machine weight (Net)		kg (lb)	12700 (27998.3)	
Control	CNC system		DN Solutions Fanuc i Plus {Fanuc 31i} *		

WHY Y-AXIS?

DOUBLE THE PRODUCTIVITY

Adding a single Y-axis to your machine allows for single-setup efficiency and a new level of accuracy.

But if you add a dual Y-axis—as you can in the PUMA TT series—the productivity difference is so striking that you won't ever go back.



DUAL POWER

The PUMA TT series doubles productivity with independently-operating left/right spindles and upper/lower turrets. What's more, the lower Y-axis increases productivity 20% more than having only an upper Y-axis. (PUMA TT1300/2100SY)

MORE VERSATILITY

With a Y-axis (or, in the case of the PUMA TT, a dual Y-axis), machine shops are capable of a wide variety of multi-axis milling cycles. That means there's a greater potential for done-in-one parts.



The DN Solutions promise, MACHINE GREATNESS, has two important meanings. The first is simple: DN Solutions makes great machines. The second is a challenge to our end-users. With a product line that is this comprehensive, accurate and reliable, we equip our customers to machine greatness. **The big question: *Why should you choose DN Solutions over other options?***

Here's why...



**MACHINE
GREATNESS™**



WHAT YOU MAKE AND HOW YOU MAKE IT MATTERS—SO MAKE IT
GREAT WITH DN SOLUTIONS.

UNBEATABLE MACHINES

You won't find a more comprehensive range or a better combination of value, performance and reliability anywhere else.

ROBUST PRODUCT LINE

We offer an impressive range of machine models and hundreds of configurations. Whatever your machining needs and requirements, there's a DN Solutions for you.

READILY AVAILABLE - ANYWHERE IN THE WORLD

Machining centres (including 5-axis machines), lathes, multi-tasking turning centres and mill-turn machines, and horizontal borers with best-in-class specifications are all available...ready to install.

EXPERT SERVICE

Our dedicated, experienced and knowledgeable team is totally committed to improving your productivity, growth and success.

CUSTOMER SUPPORT AND SERVICES

We're there for you whenever you need us.

We help our customers operate at maximum efficiency by providing them with a range of tried, tested and trusted services - from pre-sales consultancy to post-sales support.

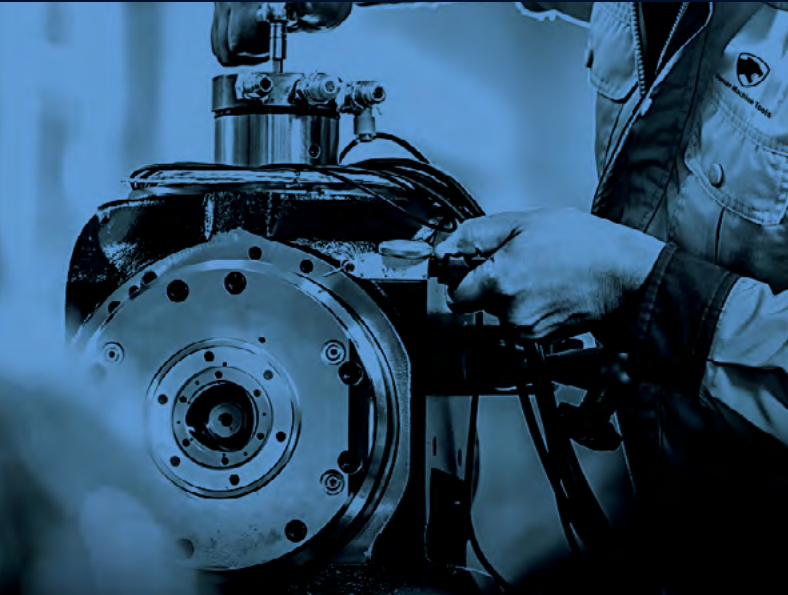

FIELD SERVICES

- On-site service
- Machine installation and testing
- Scheduled preventive maintenance
- Machine repair service

PARTS SUPPLY

- Supplying a wide range of original DN Solutions spare parts
- Parts repair service



TRAINING

- Programming, machine setup and operation
- Electrical and mechanical maintenance
- Applications engineering

TECHNICAL SUPPORT

- Supports machining methods and technology
- Responds to technical queries
- Provides technical consultancy

RESPONDING TO CUSTOMERS ANYTIME, ANYWHERE

DN Solutions Global Network

DN Solutions provides systems-based professional support services, before and after the machine tool sale, by responding quickly and efficiently to customers. By supplying spare parts, product training, field service and technical support, we provide the expert care, attention and assistance our customers expect from a market leader.



Global sales and service support network

4	Corporations
155	Dealer networks
51	Technical centers Technical Center, Sales Support, Service Support, Parts Support
200	Service posts
3	Factories





dn-solutions.com

Head Office

19F, 10, Tongil-ro, Jung-gu
Seoul, Republic of Korea, 04527
Tel: +82-2-6972-0370/0350
Fax: +82-2-6972-0400

DN Solutions America

19A Chapin Road, Pine Brook
New Jersey 07058, United States
Tel: +1-973-618-2500
Fax: +1-973-618-2501

DN Solutions Europe

Emdener Strasse 24, D-41540
Dormagen, Germany
Tel: +49-2133-5067-100
Fax: +49-2133-5067-111

DN Solutions India

No.82, Jakkuar Village
Yelahanka Hobli, Bangalore-560064
Tel: + 91-80-2205-6900
E-mail: india@dncompany.com

DN Solutions China

Room 101,201,301, Building 39 Xinzhuan
Highway No.258 Songjiang District
China Shanghai (201612)
Tel: +86 21-5445-1155
Fax: +86 21-6405-1472

Sales inquiry

sales@dncompany.com

* For more details, please contact DN Solutions.

* Specifications and information contained within this catalogue may be changed without prior notice.